

Parameter

Item	Unit	XGS25ACK-Li
Dimension		
a.Overall length (stowed)	mm	10085
Overall length (transportation)	mm	9850
b.Overall width	mm	2450
c.Overall height	mm	2830
Platform dimension	mm	2440 × 900 × 1150
d.Wheelbase	mm	3000
Max. working height	mm	25000
Max. platform height	mm	23000
Max. working range	mm	18000
Performance		
Max.load capacity	kg	300 (Unrestricted) / 460 (Restricted)
Walking speed (stowed)	km/h	6
Walking speed (elevated/extended)	km/h	0.6
Boom luffing range	°	-4~ +73
Rotation angle of turntable	°	360 continuous
Tailswing	mm	1810
Rotation angle of platform	°	160
Min. turning radius (outside)	mm	6200
Min. turning radius (inside)	mm	3000
Overall weight	kg	13500
Max. gradeability (counterweight upwards)	%	45% (24°)
Max. gradeability (counterweight downwards)	%	30% (17°)
Power source		
Power source	Ah/V	560 / 76.8 lithium battery
Power unit	kW/V	25.4 / 50 AC
Auxiliary power unit	kW/V	1.9 / 12 DC
Travel motor	kW/V	4.2 / 52 AC

Options

Anti extrusion device / Tool tray / Working light / Anti-squeeze hand-assisted track of the platform
Half-height mesh platform / Aircraft protection device / Anti-falling assembly

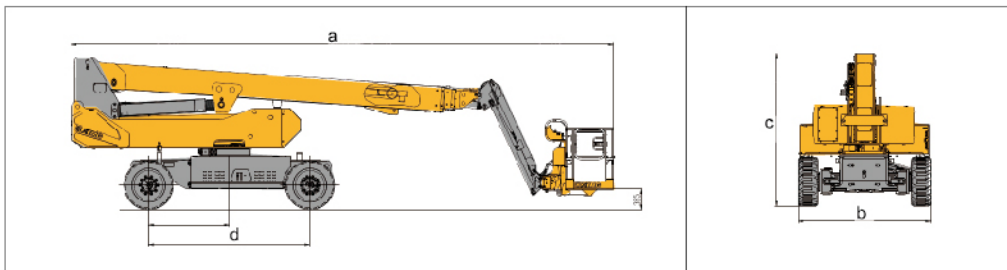

Work Curve Graph

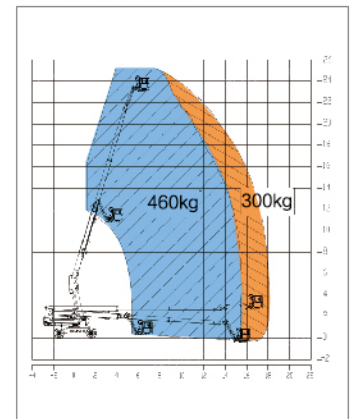

Global service hotline: 400 110 9999

