

Parameter

Item	Unit	XGA18K
Dimension		
a.Overall length(stowed)	mm	7640
Overall length(transportation)	mm	5700
b.Overall width	mm	2320
c.Overall height	mm	2380
Platform dimension	mm	1830 × 760 × 1150
d.Wheelbase	mm	2360
Max. working height	mm	18010
Max. platform height	mm	16010
Max. working range	mm	10260
Performance		
Max.load capacity	kg	256 (Unrestricted) / 350 (Restricted)
Travel speed(stowed)	km/h	5.5
Travel speed(elevated/extended)	km/h	0.6
Primary boom luffing range	°	0~65
Telescopic boom luffing range	°	-11~75
Jib luffing range	°	-65~70
Turntable rotation angle	°	360 continuous
Tailswing	mm	0
Platform rotation angle	°	160
Min.turning radius(outside)	mm	≤4700
Min.turning radius(inside)	mm	≤1900
Total weight	kg	8700
Max.gradeability(counterweight upwards)	%	45
Max.gradeability(counterweight downwards)	%	30
Power source		
Engine model	/	Yuchai YCF3050-T302/Kubota V2403-M-DI-ET04e
Rated power	kw	36.8 /36.5
Hydraulic tank capacity	L	85
Hydraulic system capacity	L	170
Fuel tank capacity	L	65

Options

Anti extrusion device / Tool tray / Working light

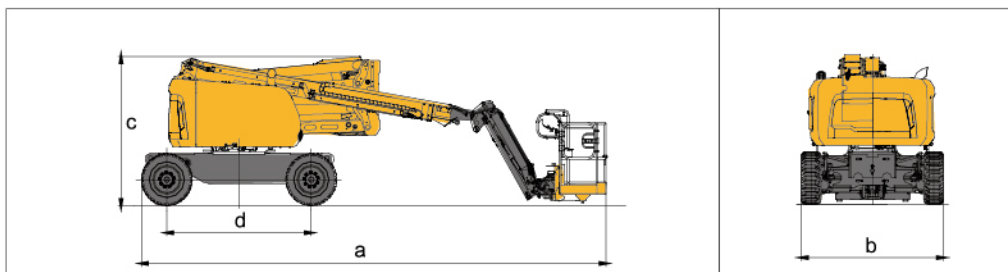

Work Curve Graph

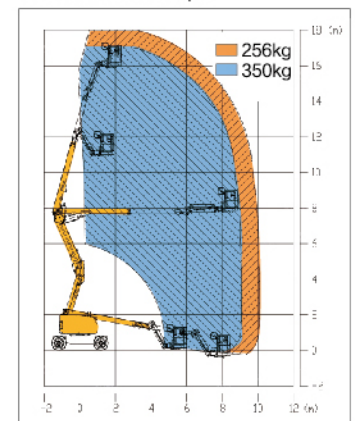

Global service hotline: 400 110 9999

